

PARTS LIST

MSD41

CONTENTS

1. CRANKCASE, INLET VALVE	1 ~ 2
2. PRESSURE REGULATOR VALVE.....	3 ~ 4
3. ACCESSORIES	5 ~ 6

2015. 04.



P/N 524075

1. MSD41
CRANKCASE, INLET VALVE

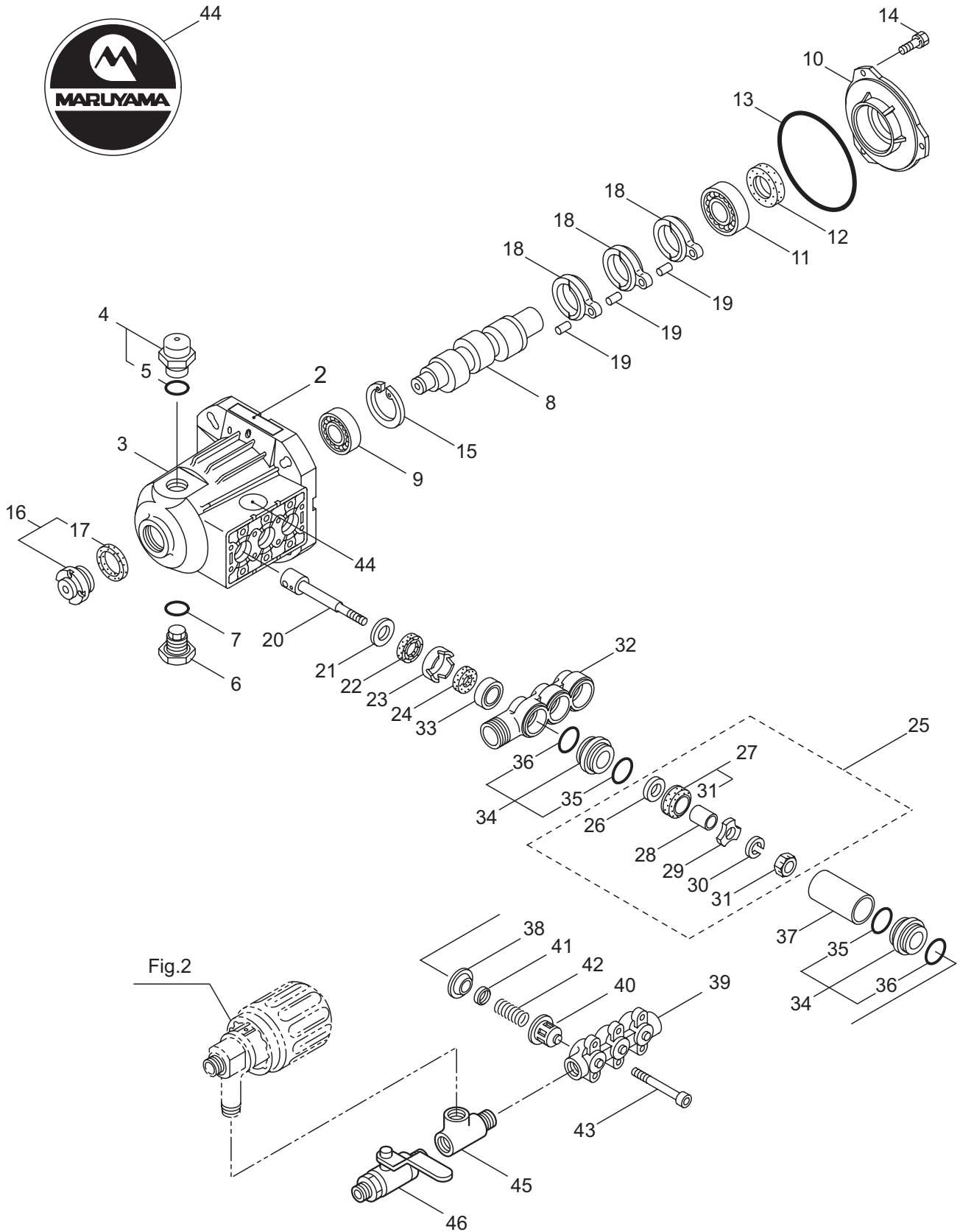

Ref. No.	Part No.	Part Name	Q'ty	Remarks
1-1	354174	MSD41	1	
1-2	548895	Label	1	MSD41
1-3	547337	Crankcase	1	
1-4	547961	Oil Filler Cap, Ass'y	1	Incl.5
1-5	014179	O-Ring	1	P20
1-6	044842	Plug	1	
1-7	014179	O-Ring	1	P20
1-8	545943	Crankshaft	1	7.0x20
1-9	015710	Bearing	1	#6204
1-10	547153	Bearing Case	1	2SF
1-11	014488	Bearing	1	#6006
1-12	055337	Oil Seal	1	D30428
1-13	014041	O-Ring	1	S100
1-14	549360	Screw	3	M6x14
1-15	012385	Snap Ring	1	H47
1-16	092241	Oil Gauge Ass'y	1	Incl.17
1-17	044428	Packing	1	25x34xt2
1-18	547046	Connecting Rod	3	2SF38MM
1-19	016948	Piston Pin	3	9x22L
1-20	830366	Piston Rod	3	
1-21	126259	Washer	3	17x24xT1.2
1-22	025461	Oil Seal	3	S10.5247
1-23	044869	Seal Retainer	3	
1-24	011402	Oil Wick	3	10x19x5
1-25	639503	Inlet Valve Ass'y	3	Incl.26-31
1-26	014122	Inlet Valva Seat	3	6.1x20xt2.8
1-27	632586	Piston Packing Set	3	Incl.31
1-28	027348	Spacer	3	6x8.5x10.5L
1-29	119917	Retainer, Piston	3	
1-30	015849	Spring Washer	3	M6
1-31	046365	Nylon Nut	1	M6
1-32	545944	Inlet Manifold	1	
1-33	540670	U-Packing	3	
1-34	546617	Discharge Adapter Ass'y	6	Incl.35,36
1-35	015862	O-Ring	6	P21
1-36	023172	O-Ring	6	P22
1-37	541811	Cylinder Pipe	3	25x28.5x43L
1-38	044881	Valve Seat	3	
1-39	544499	Discharge Manifold	1	
1-40	044565	Retainer	3	
1-41	548608	Valve	3	16x1.5
1-42	541062	Spring	3	0.6-15L
1-43	549358	Cap Screw	6	M8x110x28
1-44	545158	Label	1	
1-45	542258	Tee	1	R3/8(M)XR3/8(F)
1-46	833094	Cock Ass'y	1	R3/8xG3/8

2. MSD41 PRESSURE REGULATOR VALVE

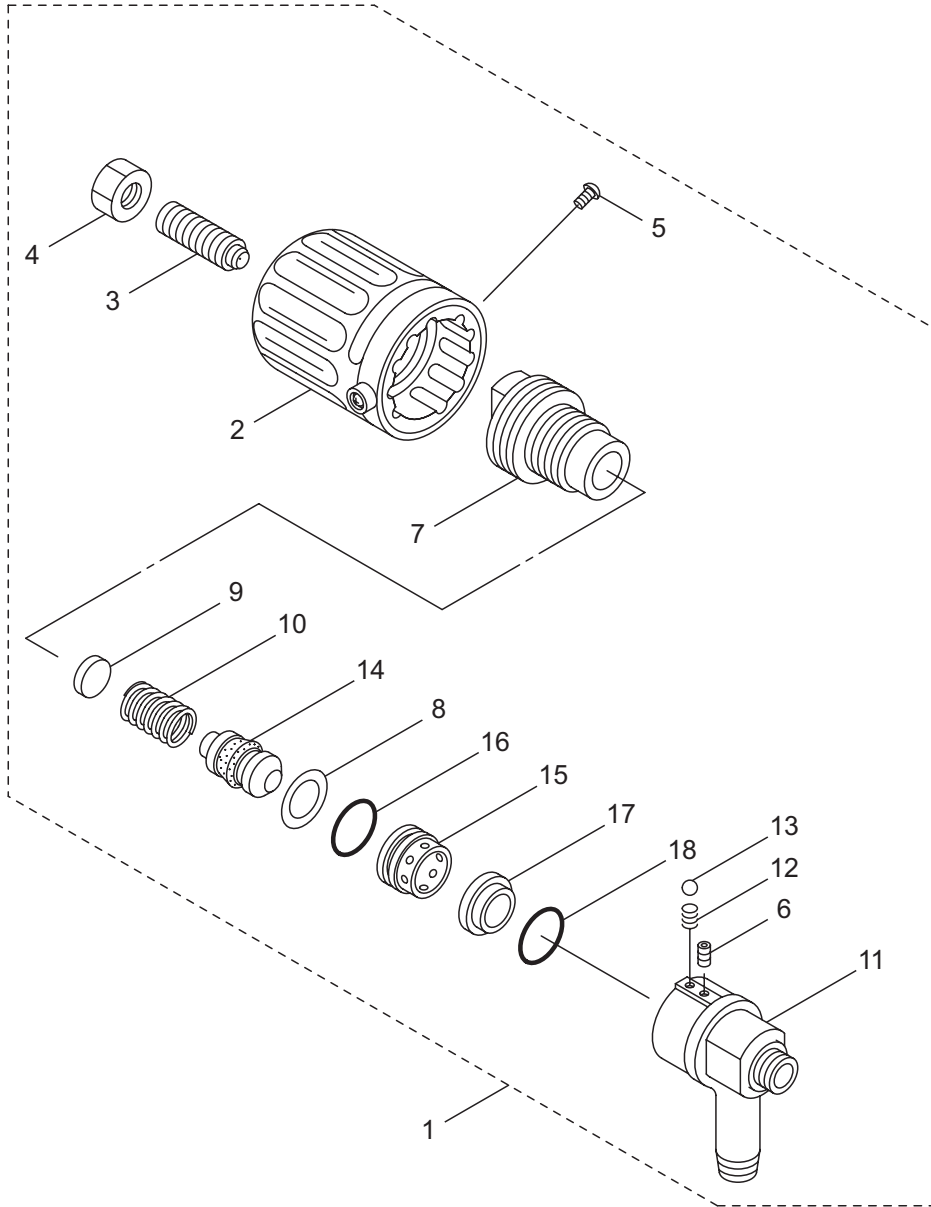

Ref. No.	Part No.	Part Name	Q'ty	Remarks
2-1	831207	Pressure Regulator Valve Ass'y	1	Incl.2-18
2-2	540936	Grip	1	
2-3	088913	Cap Screw	1	M8x35
2-4	126521	Nut	1	M8
2-5	549385	Screw	2	M3xP0.5x5
2-6	088912	Cap Screw	1	M4x6
2-7	106495	Guide	1	
2-8	106499	Washer	1	16x21xt0.7
2-9	541769	Retainer	1	15xt2.5
2-10	548819	Spring	1	3.0-31L
2-11	546500	Body	1	
2-12	107221	Spring	1	0.6-7L
2-13	106498	Ball	1	5/32(3.9688)
2-14	105724	Piston Ass'y	1	
2-15	103306	Sleeve	1	
2-16	019261	O-Ring	1	P16
2-17	103304	Valve Seat	1	
2-18	019261	O-Ring	1	P16

3. MSD41 ACCESSORIES

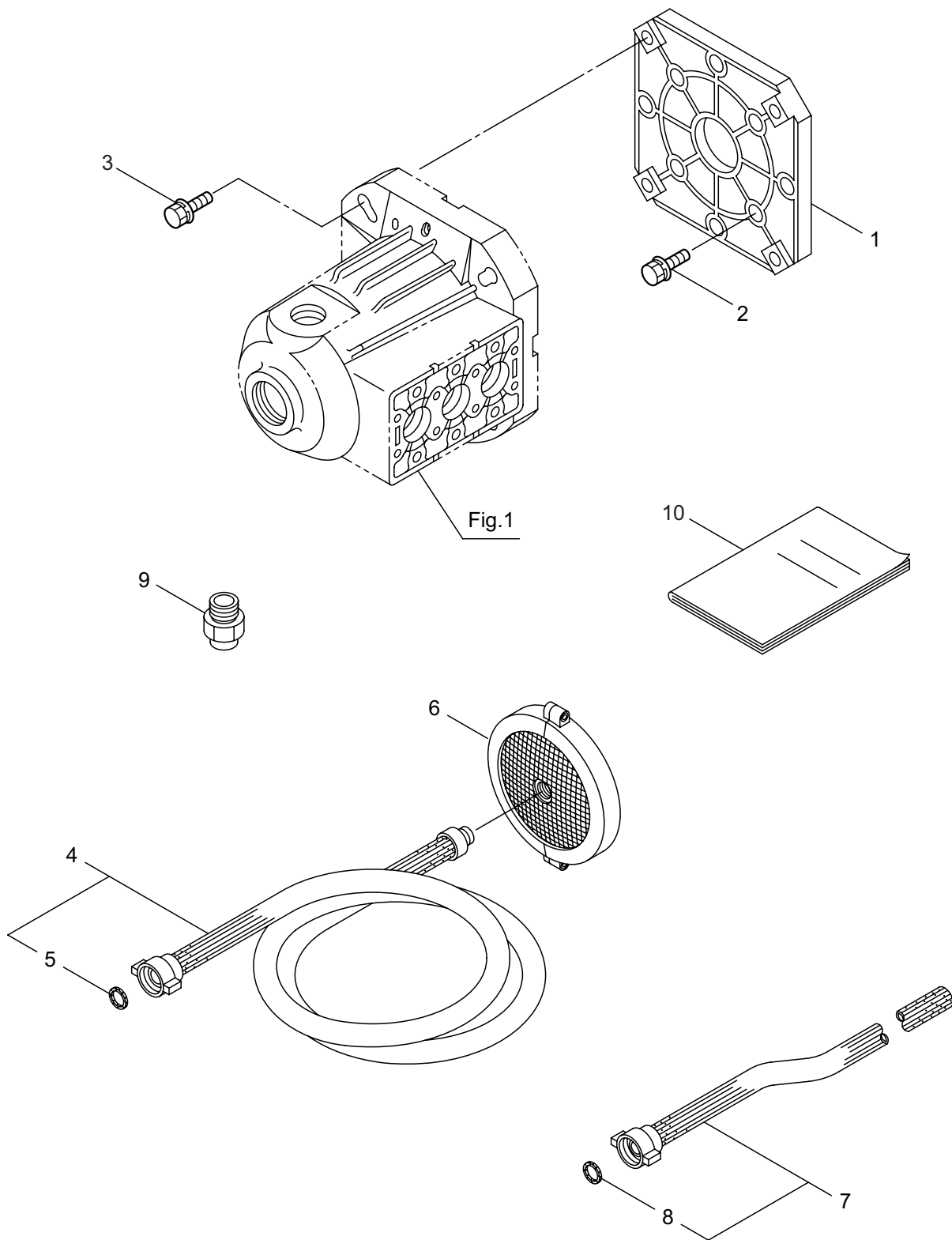

Ref. No.	Part No.	Part Name	Q'ty	Remarks
3-1	046271	Flange	1	
3-2	126763	Bolt	4	M8x20(SM)
3-3	541141	Bolt	4	3/8-35
3-4	811356	Suction Hose Ass'y	1	Incl.5 19x1Bx3000L
3-5	103686	Packing	1	18.5x24xt2
3-6	122017	Suction Strainer Ass'y	1	
3-7	811357	Spill Hose Ass'y	1	Incl.8 13x19x3000L
3-8	103685	Packing	1	12x18.5xt1.5
3-9	104260	Extension	1	G1/2xG3/8
3-10	545166	Instruction Manual	1	MSD41